

# Exploring deep learning Methods

G.Pranitha

*Department of Computer science and Engineering  
Anil Neerukonda Institute of Technology and sciences , Visakhapatnam,Andhra Pradesh, India*

P.V.Lakshmi

*Department of Computer science and Engineering  
GITAM University, , Visakhapatnam,Andhra Pradesh, India*

**Abstract-** In this paper, we are going to explore what are the various models in deep learning and where we can use this in the real world applications in an efficient way. Deep learning is the technology which is trending towards development of solutions to hard problems which cannot be solved by using the other technologies available. Deep learning is the subset of machine learning which involves more than 4 hidden layers and yields better results.

**Keywords:** – *MLPNN, CNN, RNN, RBM, and DBN.*

## I. INTRODUCTION

Deep learning is a subset of machine learning which has the networks and it is capable of learning unsupervised from unstructured or unlabeled data. Deep learning is able to learn without human supervision from the data available which is both unstructured and unlabeled. Deep learning has created new trend in the digital era, which helps us to explore large amount of data which are in all forms and all the regions of the world.

## II. LITERATURE SURVEY

In this paper we discuss about various models of deep learning and compare them with certain aspects which would yield the knowledge for an individual to know what is the purpose of each model and where it could be applied.

While deep learning algorithms feature self-learning representations, they depend upon ANNs that mirror the way the brain computes information. During the training process, algorithms use unknown elements in the input distribution to extract features, group objects and discover useful data patterns. Much like training machines for self-learning, this occurs at multiple levels, using the algorithms to build the models. Deep learning models make use of several algorithms. While no one network is considered perfect, some algorithms are better suited to perform specific tasks. To choose the right ones, it's good to gain a solid understanding of all primary algorithms.

Some of the models we discuss about are Multilayer Perceptron Neural Network (MLPNN), CNN, RNN, RBM, and DBN.

### 2.1 Multilayer Perceptron Neural Network (MLPNN)

The multilayer perceptron in deep learning helps us to design many applications. It uses a feed-forward supervised learning algorithm with up to two hidden layers to generate a set of outputs from a given set of inputs. As the name indicates, it contains more layers. The network connects multiple layers of neurons in a directed graph so that the signal will pass through nodes of many layers in one direction. The output vector is computed given the inputs and a random selection of weights in the feed-forward computational flow. The model is trained in such a way, to learn the correlation between the input and output from a training data set. The error quantity between what should be the output for a given input is computed, and training will involve the process of tuning the weights and biases to reduce the amount of error at the output layer. This process is repeated for layers which are hidden and going backward. Backpropagation will be used to make the weight & bias adjustments to be relative to the error. The error can be measured using root mean square method.

MLPNN can solve complex problems which involves many parameters especially non-linear parameters. MLPNN is used to solve problems in various categories like Image verification and reconstruction, Speech recognition, Data classification, E-commerce etc.

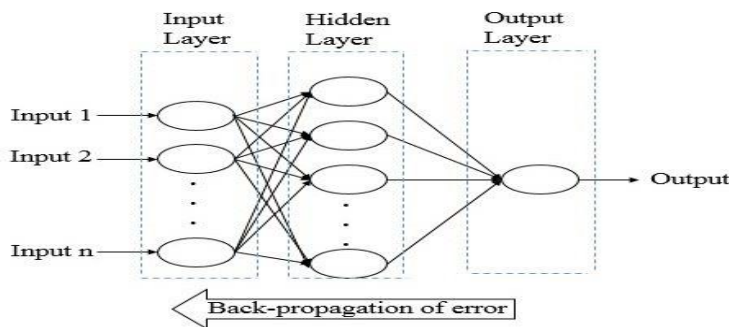

### 2.2 Convolutional Neural Network (CNN)

The convolutional neural network (CNN) is a multilayer, feed-forward neural network which uses perceptrons for supervised learning to analyze data. CNN contains three types of layers with different convolutional, pooling, and fully connected layers. In each CNN, there are two stages for the training process, the feed-forward stage, and the back-propagation stage. The most common CNN architectures are ZFNet, GoogLeNet, VGGNet, AlexNet, ResNet.

It is used mainly with visual data which involves image classification. The success of a deep convolutional architecture called AlexNet, which is the basis for the ImageNet Large Scale Visual Recognition Competition (ILSVRC), is the primary reason for more development in deep learning. CNN's are not limited to some applications like image recognition. They can be applied to text analytics and sound using graph convolutional networks.

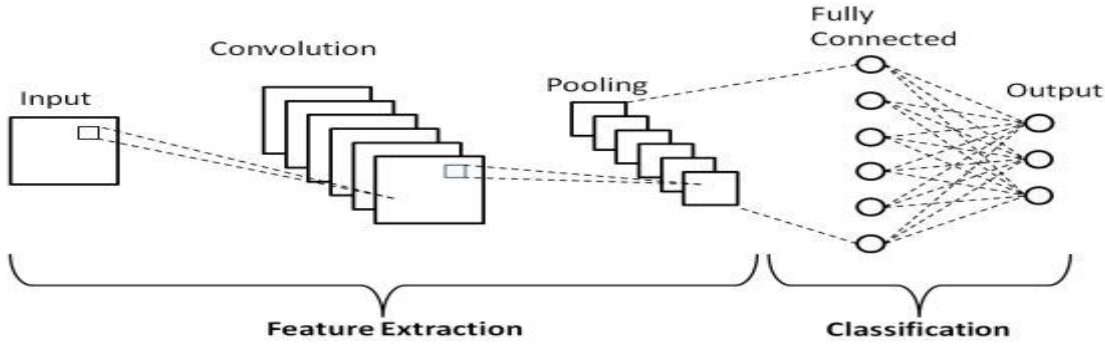

CNN architecture has difference when compared to other neural networks. To understand in a better way, now consider images as data. Typically with computer vision, images are treated as two-dimensional matrices of numbers. However, in CNNs, an image will be treated as a matrix of numbers with additional dimensions. The image below will help us to understand the concept.

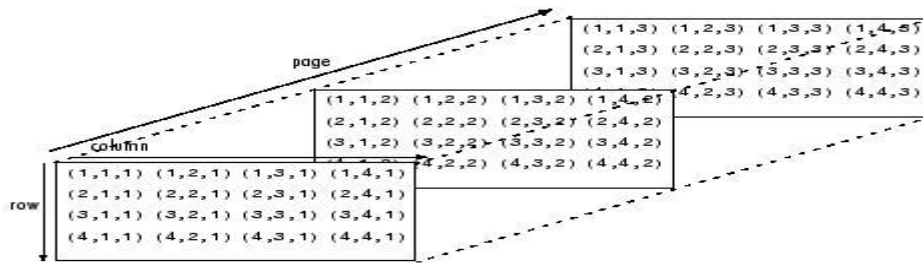

source: [skymind.ai](http://skymind.ai)

Tensors are formed by nesting arrays within arrays, with nesting potentially occurring infinitely.

Images are treated as four-dimensional tensors. If a scalar is a zero-dimensional object, a vector is one-dimensional, a matrix or collection of vectors is generally two-dimensional. It is a stack of some matrices which is three-dimensional. Then a four-dimensional tensor consists of multiple such three-dimensional objects where each element in the cube has a stack of feature maps attached to it.

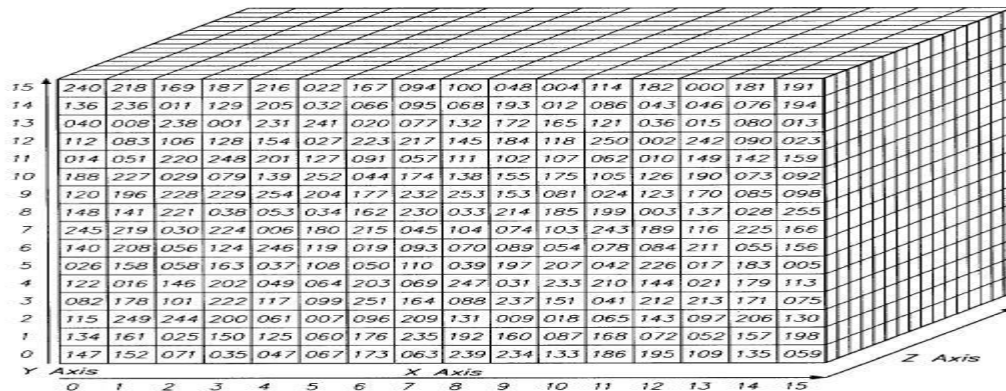

source: [skymind.ai](http://skymind.ai)

The hidden layers in CNNs contain convolutional layers, normalization layers, pooling layers, and a fully connected layer. It takes an input image, assigns significant weights and biases to various parameters of an image to enable differentiation and applies some filters to minimize

the pre-processing. Generally the first convolution layer captures low-level features and the next layers will extract higher-level features which creates a network with complex analysis of the images in the given data set. The CNN algorithm is efficient at recognition and it is highly adaptable also. It is also easy to train because there are fewer training parameters. The CNN algorithm can be used with some of the applications like image processing, video recognition, pattern recognition, medical image analysis.

### 2.3 Recurrent Neural Network (RNN)

The recurrent neural network (RNN) is designed to recognize a data set's sequential attribute. It is a good approach to processing sequential data like sound, time series data, and written natural language. The stochastic gradient descent (SGD) is used to train the network along with a backpropagation algorithm. Generally in traditional networks the inputs and outputs are independent of each other but in an RNN the hidden layer preserves sequential information from previous steps. This means the output from an earlier step is fed as the input to a current step, using the same weights and bias repeatedly for prediction purposes. The layers are then joined to create a single recurrent layer. These feedback loops will process the sequential data where it allows the information to persist in memory which informs the final output.

If an RNN is tasked with guessing the next letter of a previous input letter, it can be trained by feeding letters of known words letter by letter, so that it will determine patterns which are relevant. RNNs are layered to process the information in two directions: feed-forward (to process data from initial input to final output) and feedback loops using backpropagation (looping information back into the network). We can indicate two types of RNN. They are

#### **Bidirectional RNN:**

They work two ways; the output layer can get information from past and future states simultaneously.

#### **Deep RNN:**

Multiple layers are present. As a result, the DL model can extract more hierarchical information.

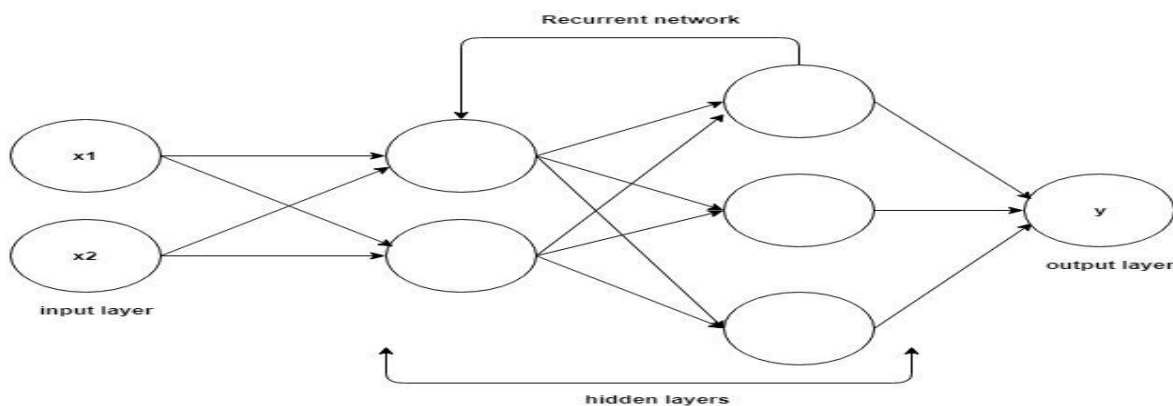

RNNs are different from feed-forward networks because feed-forward networks accept one input and give one output at a time. This one-to-one constraint does not exist with RNNs, which can refer to previous examples to form predictions based on their built-in memory.

#### 2.4 Restricted Boltzmann Machine (RBM)

The Restricted Boltzmann Machine (RBM) is a type of neural network which is a probabilistic graphical model. It has a robust architecture to perform collaborative filtering of data and it also performs a binary factor analysis with communication which is restricted between layers for efficient learning. RBMs have replaced GANs more or less by people who apply machine learning. The network has two types of layers where one type of layer is of visible unit and one type of layer is of hidden unit. These so many units of visible and hidden are connected by bias units. Hidden units are independent as a way to give unbiased samples. The neurons which are present in the bipartite graph had a symmetric connection. But there are no connections between the nodes within a group.

RBM offers the advantages of energy-based learning like design flexibility. It is useful for probabilistic and non-probabilistic statistical models, restricts connectivity for easy learning. RBM can also be used with classification, regression, and generative models. It is useful for feature learning, Topic modelling, Dimensionality reduction and filtering.

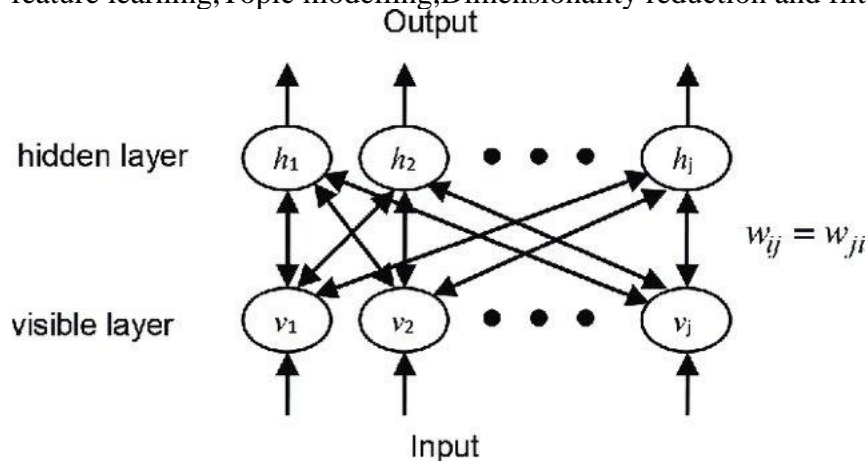

#### 2.5 Deep Belief Network (DBN)

A Deep Belief Network (DBN) is a probabilistic unsupervised deep-learning algorithm where the network has a generative learning model. It is a mix of undirected and directed graphical networks. It is organized with the top layer an undirected RBM and the lower layers directed downward. This will enable a pre-training stage and a feed-forward network to get the fine-tuning stage. DBNs are employed for high dimensional manifolds learning of data. This method contains multiple layers, including connections between the layers except for connections between units within each layer. DBNs can be considered as a hybrid multi-layered neural network, including directed and undirected connections.

The DBN has many layers of connected hidden units and learning algorithm used is “greedy” from the stacked RBMs, there is one layer at a time, sequentially from the bottom observed layer. DBNs benefit from unlabeled data and it offers the energy based learning. It is useful for video –sequence recognition, classification of high resolution satellite image data and image, face recognition, motion capture data etc.

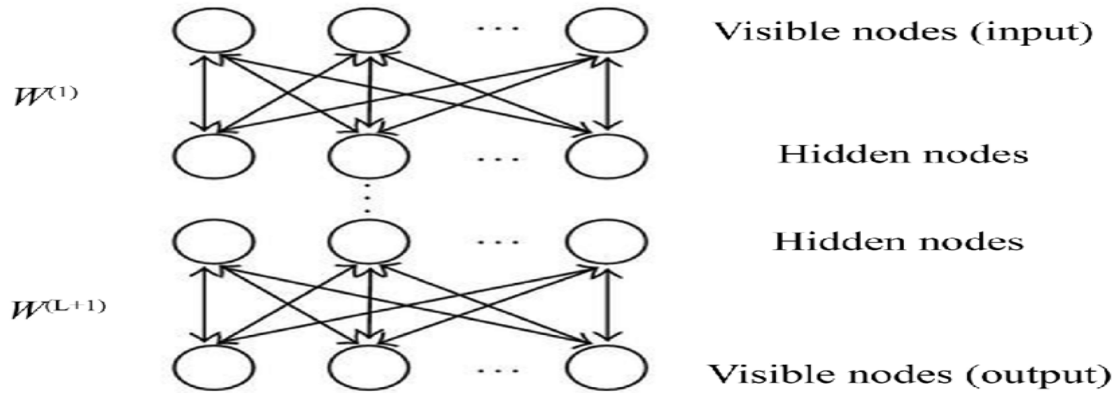

*Comparison of deep learning models*

MODEL	NO OF LAYERS	TYPES OF APPLICATIONS
Multilayer Perceptron Neural Network (MLPNN) ...	A MLPNN has three types of layers: An input layer, an output layer, and multiple hidden	Image verification and reconstruction,Speech recognition ,Machine translation,Data classification,E-commerce, Real World Applications like Data Compression - PCA Time Series Prediction Character Recognition and What-Where, Autonomous Driving - ALVINN
CONVOLUTIONAL NEURAL NETWORKS(CNN)	Convolutional Layer, Pooling Layer, and Fully-Connected Layer	Image recognition and OCR Object detection for self-driving cars,Face recognition on social media,Image analysis in healthcare,Analyzing Documents,Historic and Environmental Collections,Understanding Climate,Advertising

RECURRENT NEURAL NETWORK (RNN)	2 layers	Brand Management , Market Research, Product Analytics, language Modelling and Generating Text, Machine Translation, Speech Recognition, Generating Image Descriptions, Video Tagging Text Summarization, Call Center Analysis Face detection, OCR Applications as Image Recognition and Other applications like Music composition
Restricted Boltzmann Machine (RBM)	Visible and hidden units form two layers of the RBM	Dimensionality reduction, classification, collaborative filtering, feature learning, topic modelling
Deep Belief Network (DBN)	The DBN itself consists of three hidden layers with 1000 units per layer.	electroencephalography, <sup>[5]</sup> drug discovery, Image recognition, Video recognition, Motion-capture data

#### IV. CONCLUSION

Deep learning methods are fast-evolving in research and many applications. We have described the number of layers and different types of applications where they can be applied. This paper aims at providing a comprehensive list of the most popular deep learning methods and provide the type of applications where they can be used to ease the researcher to find the different models like MLPN, CNN, RNN, DBN, RBM methods. This can be extended by in-deep understanding of each model.

#### V. REFERENCES

- [1] AJAY SHRESTHA AND AUSIF MAHMOOD, "REVIEW OF DEEP LEARNING ALGORITHMS AND ARCHITECTURES", IEEE VOL 7 2019.
- [2] Samira Pouyanfer, Saad Sadiq, "A SURVEY ON DEEP LEARNING: ALGORITHMS, TECHNIQUES, AND APPLICATIONS:", ACM Computing surveys, September 2018.
- [3] PAN WANG 1, XUEJIAO CHEN2, FENG YE 3 AND ZHIXIN SUN 1, "A Survey of Techniques for Mobile Service Encrypted Traffic Classification Using Deep Learning" IEEE, MAY 2019.
- [4] Mohammad Hesam Hesamian, Wenjing Jia, Xiangjian He, Paul Kennedy, "Deep Learning Techniques for Medical Image Segmentation: Achievements and Challenges, MAY 2019

[5] Chuanqi Tan, Fuchun Sun, Tao Kon, "A Survey on Deep Transfer Learning", Springer April 2018.

[6] Guowen Xu; Hongwei Li; Hao Ren; "Data Security Issues in Deep Learning: Attacks, Countermeasures, and Opportunities", November 2019